

FORMTEGNING
Sett fra overside form

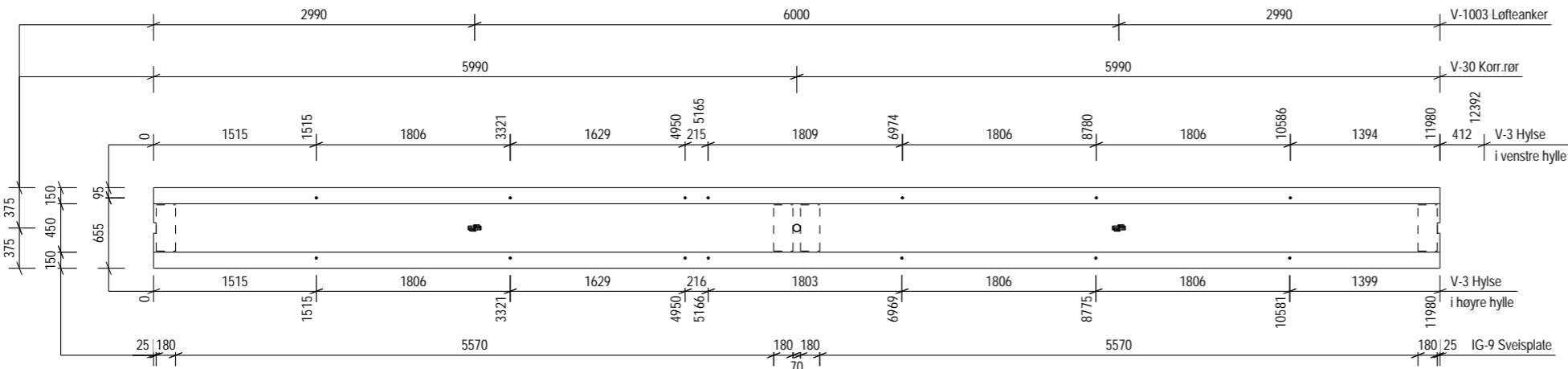

INNSTØPINGSGODS
Sett fra overside form

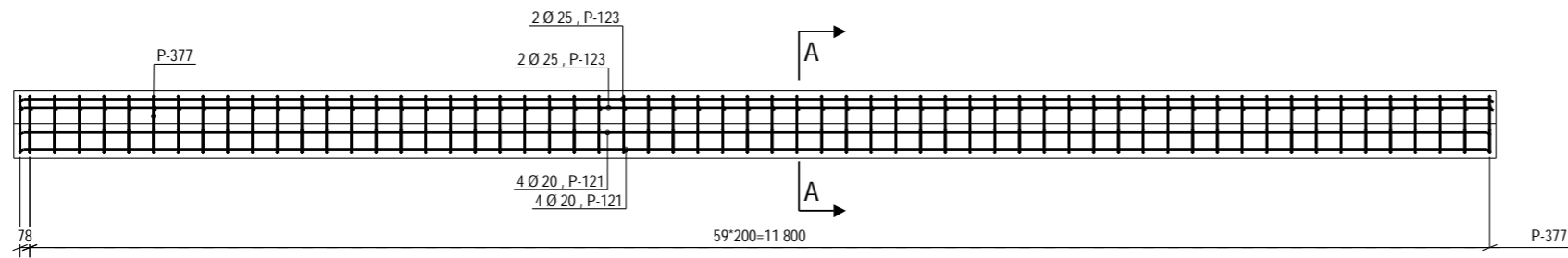

ARMERING
Sett fra overside form

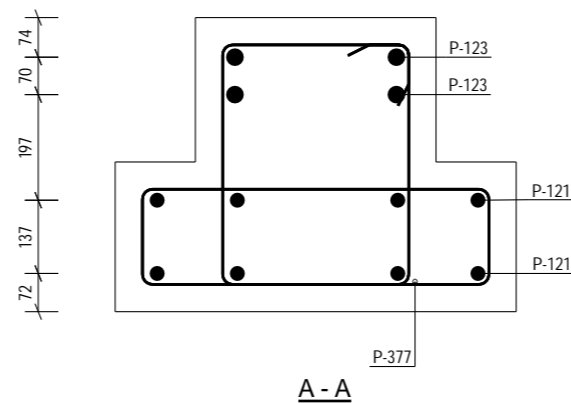

A - A

ARMERING													
Pos	Ant	Kval.	Dia.	L	Kode	A	B	C	D	E	Krok	IR	MERKNAD
P-121	8	B500NC	20	11910	00	11910							
P-123	4	B500NC	25	11930	00	11930							
P-377	61	B500NC	10	3405	99								

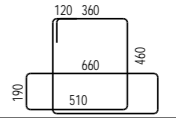

INNSTØPINGSGODS					
Pos	Ant	Navn	Beskrivelse	Overflate	Kvalitet
IG-9	4	Sveisplate	430x180x15	Primet	S355J0
V-3	14	M16 x140 GV	0020.010-00003		0
V-30	1	Korr rør	D70, L=550		0
V-1003	2	TPA-FS-7,5-26	Løfteanker		0

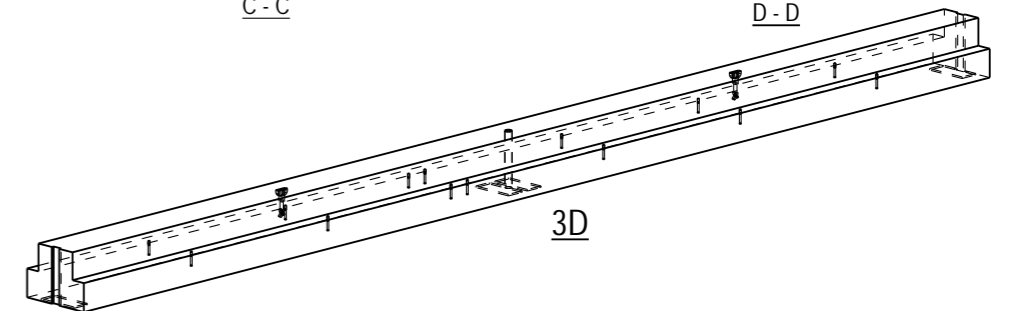
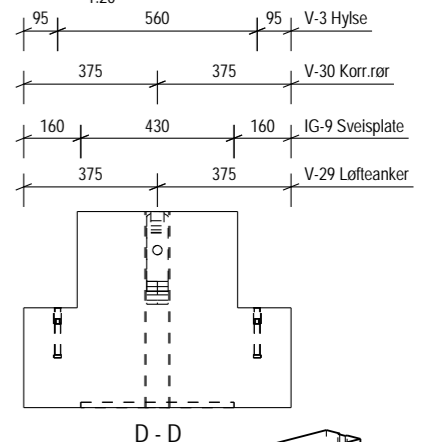
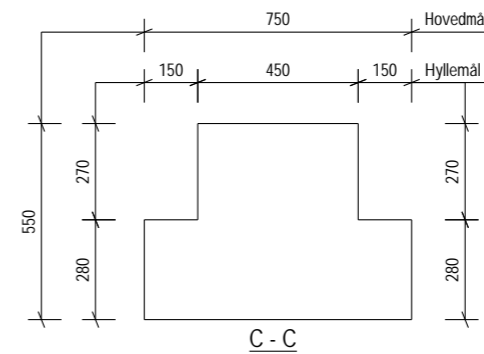
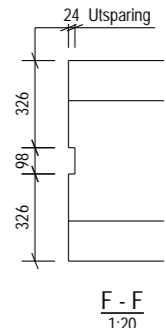
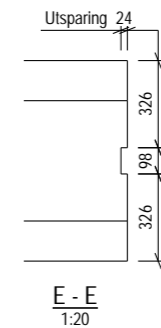

Merknader	
Vekt	9.97 tonn
Toleranse	+5mm
Kontrollklasse	Normal
Trykkfasthet	B35
Overflate NED	Grå glatt
Overflate OPP	Grå glatt
Luft	
Bestandighetskl.	M45
Eksponeringskl.	XS1
Brannklasse	R30
dmaks	16
Overdekning	45+5mm
Fas	10 mm

REV	ANT	REVISJONEN GJELDER	Dato	Sign.
Stjern Belsvik RAS 2			Dato	Sign.
Tegnet av			28.01.2021	TG
Kontrollert av			28.01.2021	KL
Godkjent av			28.01.2021	TG
Status				
Proj. nr.			Målestokk	
2020029				
Tegn.nr.			Rev.	
DLB-1120				

BETONGBYGG

Telefon : 74 28 06 00